



## BALL VALVE

**Series:** 32000TR-N, 32500TR-N, 34000TR-N, 34200TR-N, 34300TR-N, 34500TR-N, 35000TR-N, 35200TR-N, 35300TR-N, 35500TR-N, 36000TR-N, 36500TR-N, 39000TR-N, 39200TR-N, 39300TR-N, 39500TR-N, 440TS-N, 442TS-N, 443TS-N, 445TS-N, 467TS-N, 468TS-N.



## INSTRUCTION FOR INSTALLATION, USE AND MAINTENANCE

### 1. Overview

Read these instructions carefully before starting the valve installation and start-up work. Safe keep the instructions in the proximity of the valve for easy access by the valve operators.

**HÖGFORS OY takes no responsibility for any damage caused by the valve's incorrect transportation, handling, installation or use.**

The warranty covers defects in workmanship or material.

HÖGFORS OY grants a one-year warranty on all of its products, but the warranty is at most two (2) years from the delivery of product.

In order to obtain warranty compensation, the defective product shall be sent to manufacturer or presented to manufacturer's representative at site for investigation.

More detail warranty obligations see Orgalime S 2000.

### 2. Factors to be considered prior to installation and commissioning.

During the receiving inspection, check that the valve and its accessories are free from any transportation-induced damage. During storage the valve must be exposed to dirt, rain, prolonged sunshine or sub-zero temperatures.

Always make sure before installation that the valve is suitable for the medium.

- Steel valves can be used in district heating (not with steam), heat piping, oil piping and with oxygen-free water.
- Stainless steel materials are suitable for use in process piping and compressed air lines, with acids, bases, raw water and oxygen-rich water, i.e. in applications that require good corrosion resistance.

### 3. Installation.

The valve or actuator operation is not limited by the direction of flow or the position in which the unit is fitted. The valve should not be fitted at the lowest point of the pipework or in over low-level locations.

The pipework should be carefully cleaned before the valve is fitted. Remove any foreign matter that may have got into the valve during transportation or storing.

Test the proper operation by opening and shutting the valve.



Högfors recommend the use of electric welding methods. If gas welding cannot be avoided, always cool the valve with wet rags during welding, and do not gas weld valves size >DN125.

Make sure the chamfering of the piping is suitable for welding of the valve.

Do not remove the protective covers of the connections until just before installation.

Welding to be performed by a qualified welder.

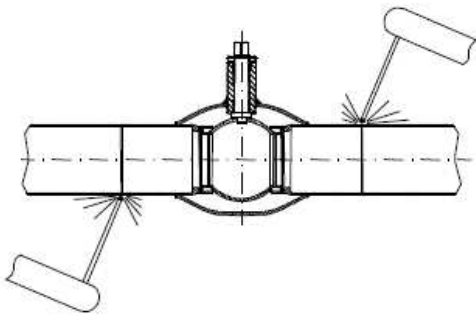

The valve shall be completely open when welded into horizontal piping.

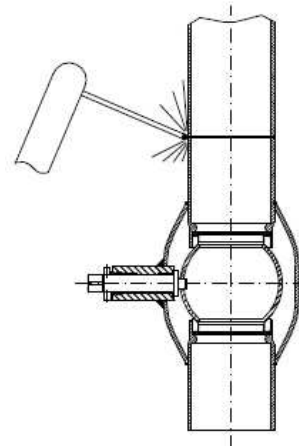

When welding the valve into vertical piping, the valve shall be open when the upper seam is welded.

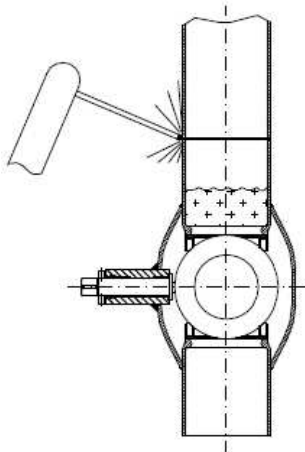

If the valve is closed when the upper seam is welded, it must be filled with water.

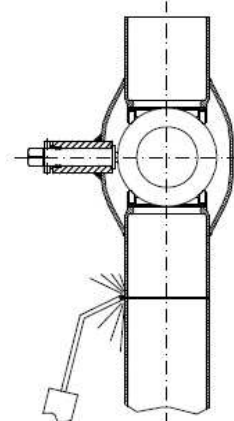

In gas welding the valve shall be closed when welding the bottom seam.

Excessive heating of the valve must be avoided during the welding. The valve must be cooled down using e.g. a damp cloth, cooling paste etc. Resume work using shorter welding times.

It is recommended that the handle be removed from the valve for installation.



Do not turn the ball until the valve is completely cooled after welding. After installation, flush out the pipework through, and leave the valve either fully open or fully closed.

During designing and construction of valve elements, uncontrolled thermal expansion of the pipeline media has to be prevented.

### 3.1 Pressure test

- Perform a pressure test at 1.1 x PN with the valve connected into the network and in closed position. Perform a pressure test at 1.5 x PN with the valve completely or partly open. Check the valve against leaks.

### 3.2 Valve support

- Typically support methods used with piping are employed. With valves smaller than DN 50 no special supports are needed, but for valves larger than DN 50 local support instructions shall be complied with.

## 4. Operation

A valve designed for use as a shut-off valve may only be used in the open/closed position.

Avoid unnecessarily fast closing of the valve due to pressure shocks. For larger sizes ( $\geq$  DN 150), a by-pass valve is recommended.

In applications where the valve remains in the same position for most of the time, it can be opened or closed a few times during the year to avoid seizing of the valve.

In exceptionally corrosive applications, special protection of the valve body and connections should be employed.

If the valve is the only pressure-bearing component at the end of the line, the valve must be plugged with a flange, plug or by some corresponding means.

The valves can be operated using the handle or an actuator.

## 5. Maintenance

The valves require no maintenance in normal conditions. However, the O rings on the stem can be replaced, if needed.

### 5.1 Replacement of O rings on the stem

- DN15 – 50 (full opening DN10-40) the top O-ring can be replaced. Detailed instructions are given in the replacement instructions of O-rings.
- DN65 (full opening DN50) – DN150 and DN300 the top two O-rings can be replaced. DN200 and DN200 the top O-ring can be replaced. Detailed instructions are given in the replacement instructions of O-rings.

5.2 The valve shall be depressurized for maintenance, if it is not disconnected from the line.

5.3 The valve shall be in closed position for the replacement of O-rings.

5.4 The valve must be depressurized before it is removed from the piping.

5.5 Protective gear shall be worn when replacing O-rings.

5.6 Do not open the valve until all the required components have been replaced.



## 6. Exploded view and standard materials

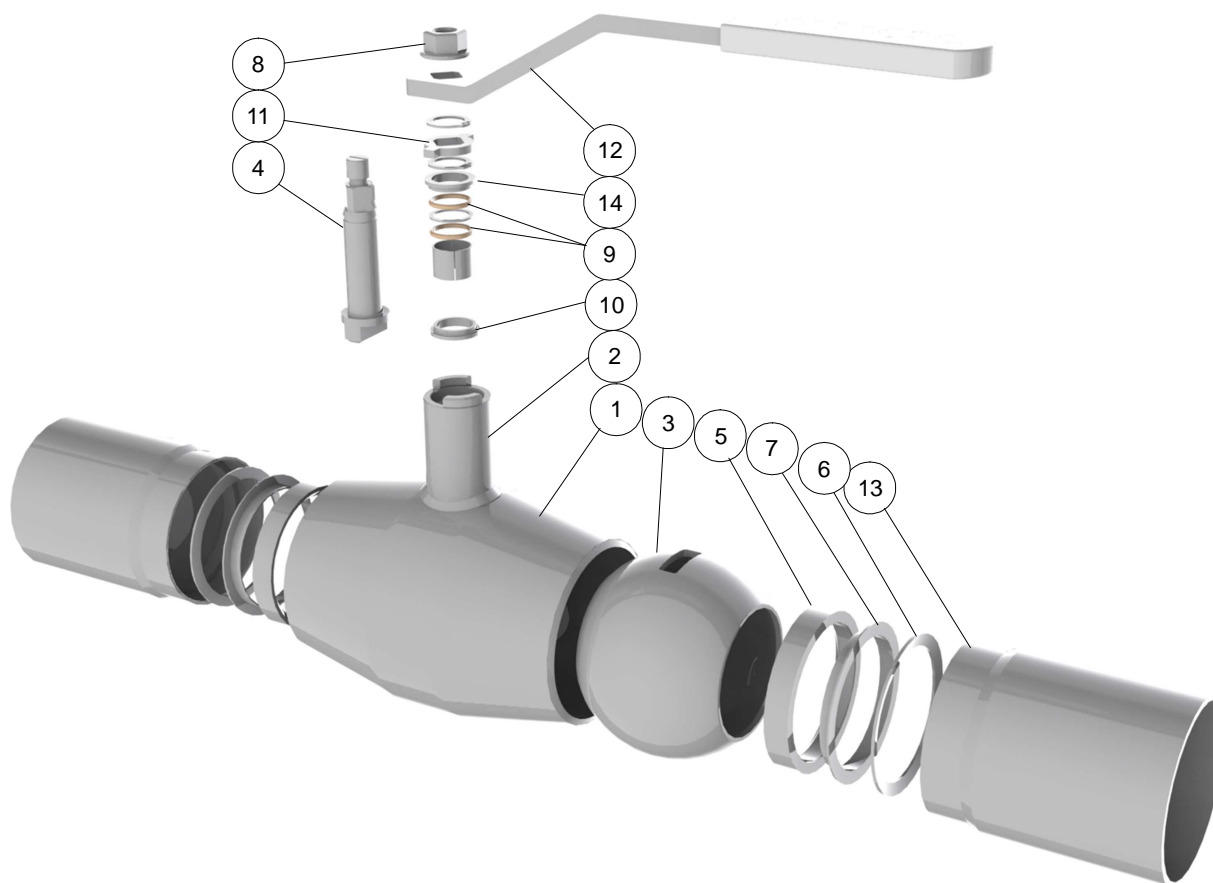

Part	Material *		
	340 DN10-500	340 DN600	440
1 Body	Carbon steel P235GH	Carbon steel W1.0345	Stainless steel 1.4404
2 Stem housing	Carbon steel P355NH	Carbon steel W1.0425	Stainless steel 1.4404
3 Ball	Stainless steel 1.4301	Stainless steel W1.4301	Stainless steel 1.4404
4 Stem	Stainless steel 1.4305	Stainless steel W1.4460	Stainless steel 1.4404
5 Seal	Teflon PTFE+C		
6 Bevel washer	Spring steel	Steel	Stainless steel 1.4404
7 Support ring	Stainless steel	Steel	Stainless steel 1.4404
8 Screw	Steel		Stainless steel
9 O-ring	FPM	EPDM	FPM
10 Thrust washer	Teflon PTFE		
11 Stop	Stainless steel 1.4016 / 1.4404		Stainless steel 1.4404
12 Handle	Zinc-plated steel		Stainless steel (DN10-50) Zinc-plated steel (DN65-250)
13 End pipe	Carbon steel P235GH	Carbon steel ASTM GWCC	Stainless steel 1.4404
14 Bushing			Stainless steel 1.4305

\*Materials can vary in different series. See separate Product card for detail.